

GREAZZAPPER[®]

2000 4000

Kitchen Exhaust Pollution Control

- ❑ OPTIONAL VERTICAL AIR INLET WITH DRAIN (SEE DWG)
- ❑ OPTIONAL OUTDOOR PACKAGE - WEATHERHOOD/UTILITY FAN/HEAT TRACE
- ❑ OPTIONAL AUTOWASH MODULE- 3/4" WATER INLET/140°F/25PSI (SEE DWG)
- ❑ OPTIONAL 8000 CFM CAPACITY (SEE DWG FOR DIMENSIONAL INCREASE)
- ❑ OPTIONAL 25% MORE AIR CAPACITY- DOUBLES NOISE LEVEL TO 80 dBA
- ❑ OPTIONAL SECOND ODOR MODULE (HOUSING ONLY) – ADDS 2 FT TO LENGTH
- ❑ OPTIONAL GREEN OPTION (VFD AND PHOTOHELIC FOR MIN. CONSTANT AIRFLOW)
- ❑ OPTIONAL FULL ANSUL SYSTEM (UNDER DEVELOPMENT)

AEROSOL REMOVAL EFFICIENCY
95% ASHRAE 52.2 AND ASTM 2519

EXHAUST FAN DATA
230 V 3PH WITH STARTER

GREAZZAPPER WEIGHT

2000	1200 -1800 LBS.
4000	1500 - 2500 LBS.
8000	2400 - 4400 LBS.

CFM	HP	TSP	dBA	FLA
2000	3-5	3-5	70-75	13
4000	5-7.5	3-6	75-80	20
8000	10-15	4-6	77-80	29

AGENCY LISTINGS
ETL # 483070
NYC MEA# 96-04-E
LA RR# 8452

GREAZZAPPER STATIC PRESS LOSS

DP	STATIC PRESS LOSS		CARBON
	STD	+25%	
INITIAL	1.50	2.00	+ 0.50
FINAL	1.50	2.50	+ 0.50

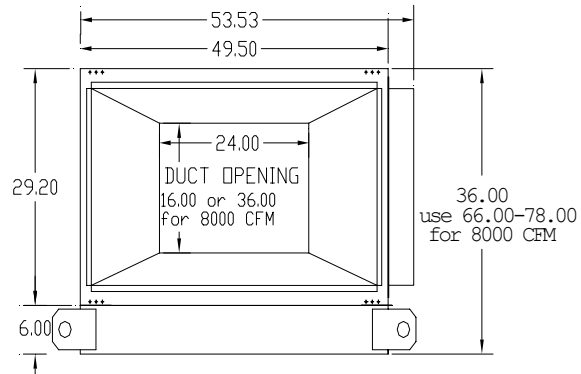

STANDARD HORIZONTAL AIR INLET

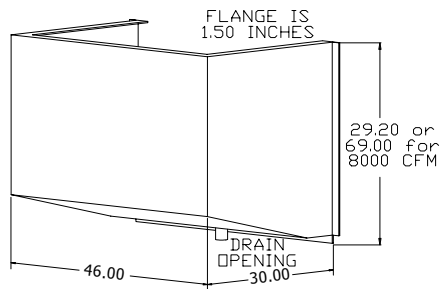

VERTICAL AIR INLET WITH DRAIN

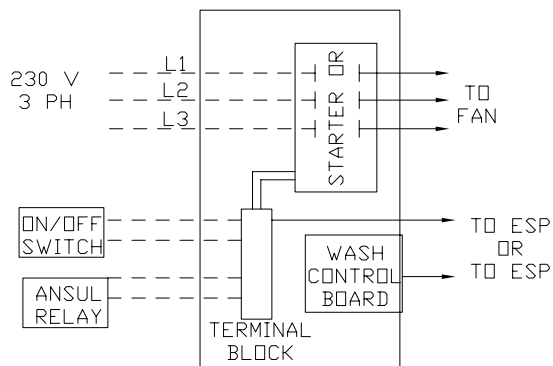
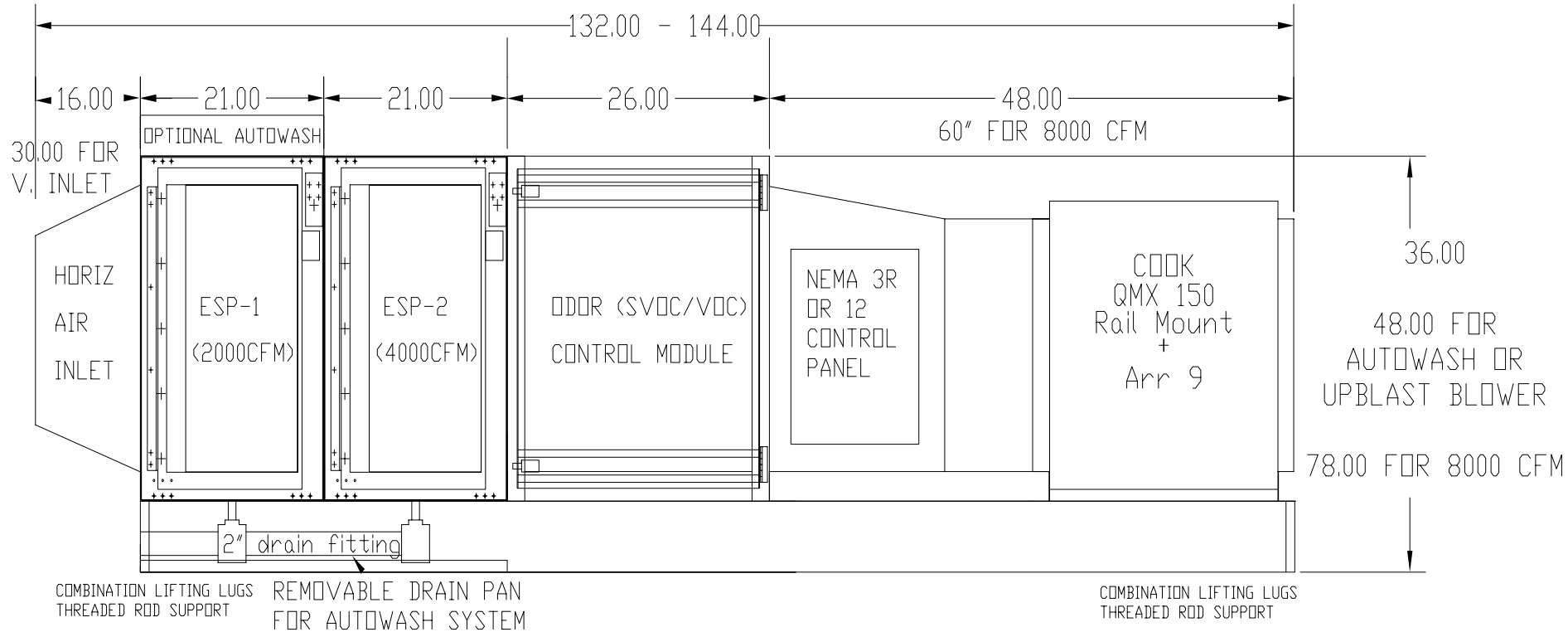

FIELD WIRING TO CONTROL PANEL

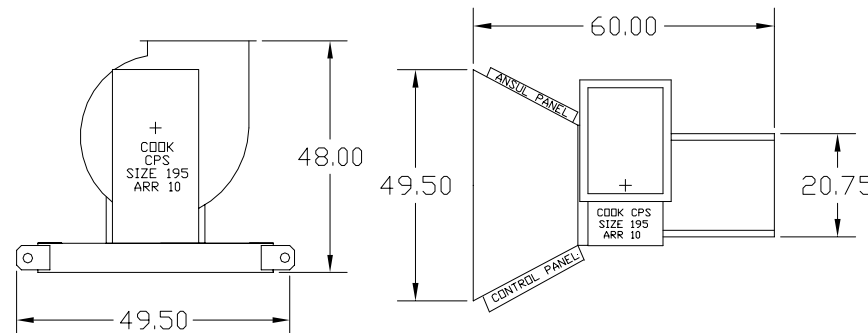

OPTIONAL OUTDOOR UPBLAST FAN with PLAN VIEW

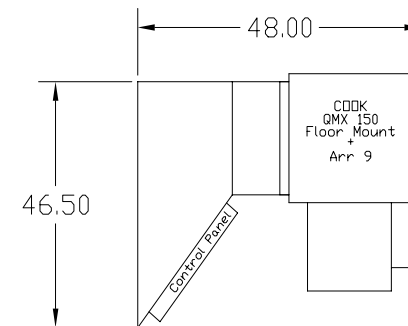

PLAN VIEW OF STANDARD FAN

GREEN
Kitchen
DESIGNS

Ph: (866) 669-0966
Fax: (866) 667-0466
www.GrKD.com